

**WIRING DIAGRAMS**  
**Article Text**  
 1986 Volkswagen Quantum  
 For <http://volkswagen.msk.ru>  
 Copyright © 1998 Mitchell Repair Information Company, LLC  
 Sunday, January 28, 2001 11:53PM

**ARTICLE BEGINNING**

1986 Wiring Diagrams  
 Volkswagen

Quantum & Quantum Synchro

**COMPONENT LOCATION MENU**

COMPONENT LOCATIONS TABLE

Component	Figure No. (Location)
A/C COMP CLUTCH	2 (F 8)
A/C HI PRES SWITCH	2 (E 5)
A/C THERMOSTAT	2 (E 8)
A/C TIME DELAY RLY	2 (E 9)
A/C SWITCH	4 (B 16)
ALTERNATOR	2 (B 2)
AUX AIR REG	1 (E 3)
BACK-UP LT SWITCH	2 (D 7)
BATTERY	1 (A 2)
BEAM SELECT SW	5 (A-B 20)
BRAKE WARN SWITCH	1 (D 2)
CAT ELAPSED MILE COUNTER	5 (A 21)
CENTRAL LOCK	6 (D-E 26)
CIG LTR	5 (D 20)
COLD START VALVE	1 (B 3, C 3)
COLNT LOW LEVEL CTRL UNIT	4 (F 18)
COLNT LOW LEVEL SW	4 (F 18)
COLNT TEMP SENDER	4 (F 17)
DEFOGGER GRID	6 (B 28)
DEFOGGER SWITCH	5 (F 23)
DIFF LOCK IND	5 (D-E 19)
DIR SWITCH	4 (F 16)
DOOR SWITCHES	5 (E 19-20)
FRESH AIR FAN SW	4 (A 14, A 15)
FRONT INTERIOR LT	5 (F 19-20)
FUEL TANK UNIT	6 (C 28)
FUSE #23	3 (B 9-10)
FUSE #37	6 (A 24)
FUSE/RLY PANEL	3 (A-F 10-12)
GEAR SEL SW	2 (D 8)
GLOVE COMPT LT	5 (C 19)
HAZARD SWITCH	4 (F 14-15)
HEATER CTRL ILLUM LT	4 (F 15)
HORNS	1 (C-D 1)
HORN SWITCH	3 (B 9)
IDLE STAB CTRL UNIT	1 (D 4)
IGNITION COIL	1, 2 (E 1, B 8-9)
IGNITION CTRL UNIT	1, 2 (F 1, A 9)
IGNITION SWITCH	4 (D 17-18)

# WIRING DIAGRAMS

## Article Text (p. 2)

1986 Volkswagen Quantum

For <http://volkswagen.msk.ru>

Copyright © 1998 Mitchell Repair Information Company, LLC

Sunday, January 28, 2001 11:53PM

INST CLUSTER .....	5 (A-D 23)
INTERIOR LT DELAY CTRL .....	5 (F 19)
LEFT FRONT DOOR SW .....	5 (E 20)
LIGHT SWITCH .....	5 (A-B 19-20)
LT SW ILLUM LT .....	5 (C 19)
OIL PRES SW .....	2 (F 6)
OUTSIDE TEMP SW .....	2 (E 7)
OXS CTRL UNIT (4 CYL) .....	1 (E-F 4)
OXS CTRL UNIT (5 CYL) .....	1 (A 5-7)
PARK BRAKE SWITCH .....	3 (E 9)
POWER ANTENNA .....	6 (F 25-26)
POWER MIRRORS .....	6 (D-E 23-26)
POWER WINDOWS .....	6 (A-C 23-27)
POWER WDO RLY .....	6 (A 23-24)
RAD COOLANT FAN RLY .....	2 (D-E 4)
RAD COLNT FAN AFTER RUN RELAY .....	2 (C 5)
RAD COLNT FAN AFTER RUN THERMO SWITCH .....	2 (C 5)
RADIO .....	5 (D 19)
REAR WASHER MOTOR .....	6 (E 28)
REAR WIPER MOTOR .....	6 (D-E 28)
SEAT BELT/BRAKE WARN IND .....	5 (E 23)
SEAT BELT SW .....	5 (E-F 20)
STARTER .....	1 (A 3-4)
STOP LT SWITCH .....	3 (E 13)
SUNROOF .....	6 (E-F 23-25)
THERMO TIME SWITCH .....	1 (B 4, C 4)
TRUNK LT .....	5 (F 21)
UPSHIFT SWITCHES .....	2 (E-F 6)
WASHER MOTOR .....	1 (D 3)
W/SHIELD WIPER MTR .....	1 (C-D 4)
W/SHIELD WIPER SW .....	4 (D 14-16)

---

## WIRING DIAGRAM

# WIRING DIAGRAMS

## Article Text (p. 3)

### 1986 Volkswagen Quantum

For <http://volkswagen.msk.ru>  
 Copyright © 1998 Mitchell Repair Information Company, LLC  
 Sunday, January 28, 2001 11:53PM

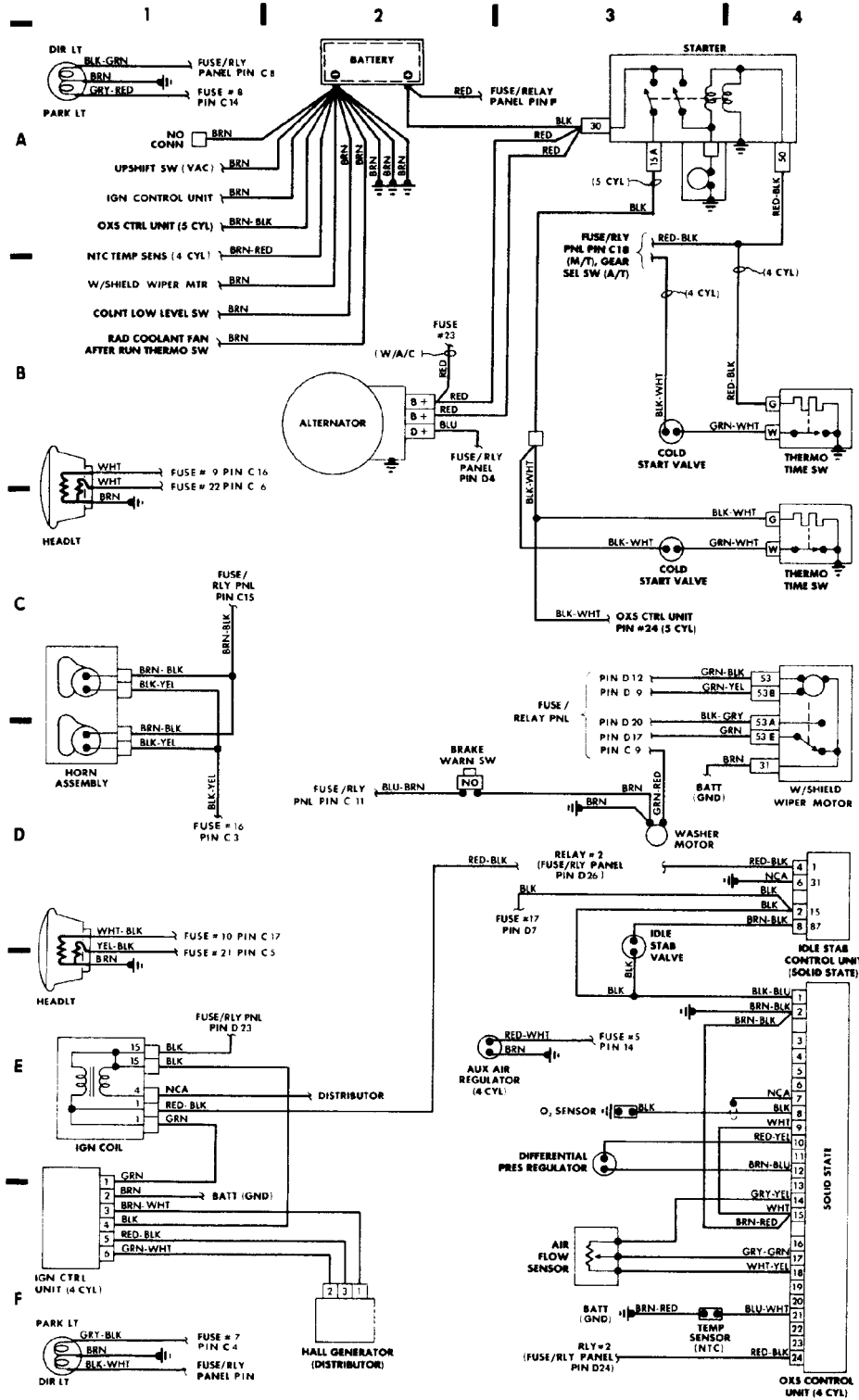

Fig. 1: Engine Compartment (Grids 1-4)

**WIRING DIAGRAMS**  
**Article Text (p. 4)**  
 1986 Volkswagen Quantum  
 For <http://volkswagen.msk.ru>  
 Copyright © 1998 Mitchell Repair Information Company, LLC  
 Sunday, January 28, 2001 11:53PM

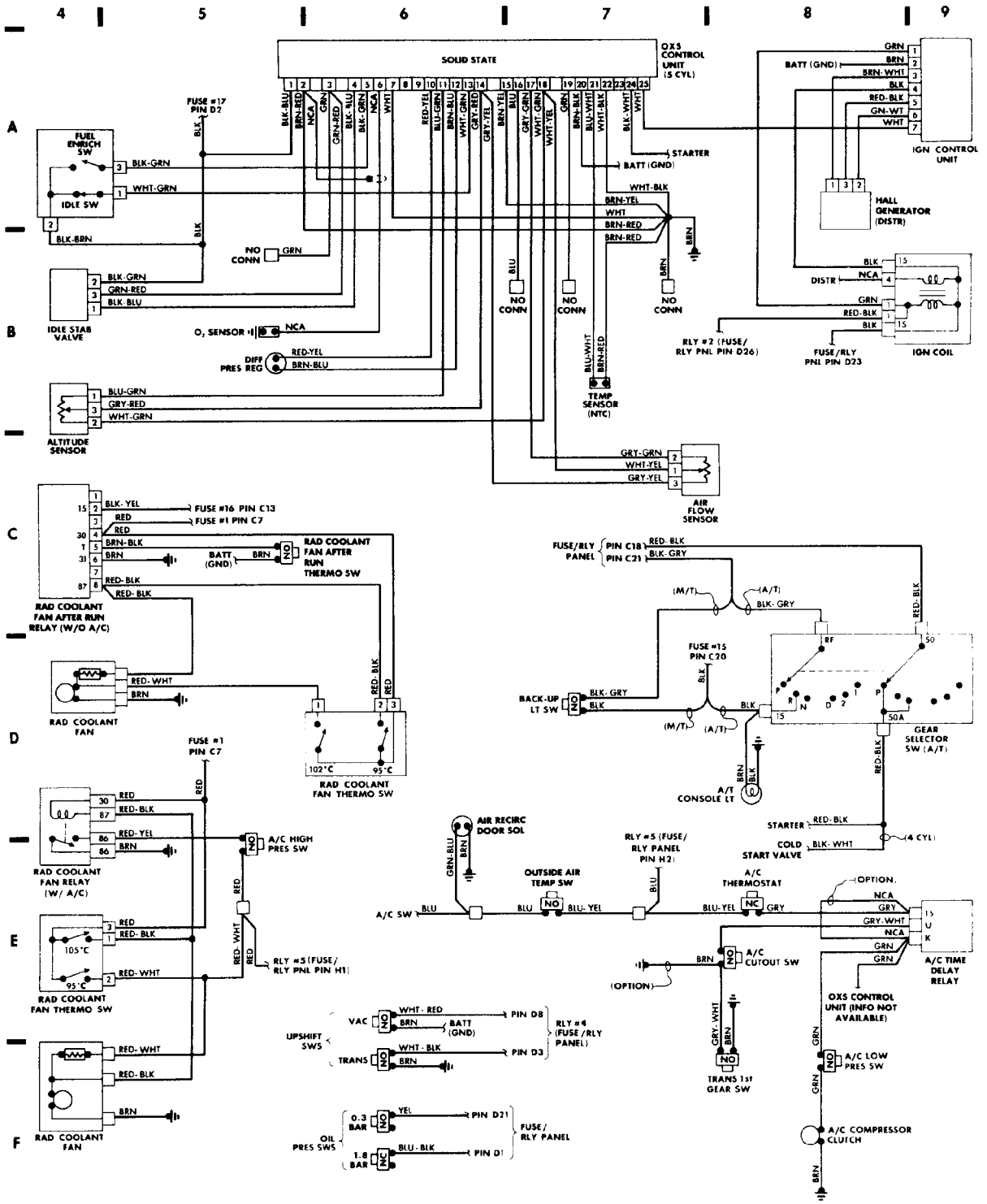

Fig. 2: Engine Compartment (Cont.) & Underdash (Grids 4-9)

**WIRING DIAGRAMS**  
**Article Text (p. 5)**  
 1986 Volkswagen Quantum  
 For <http://volkswagen.msk.ru>  
 Copyright © 1998 Mitchell Repair Information Company, LLC  
 Sunday, January 28, 2001 11:53PM

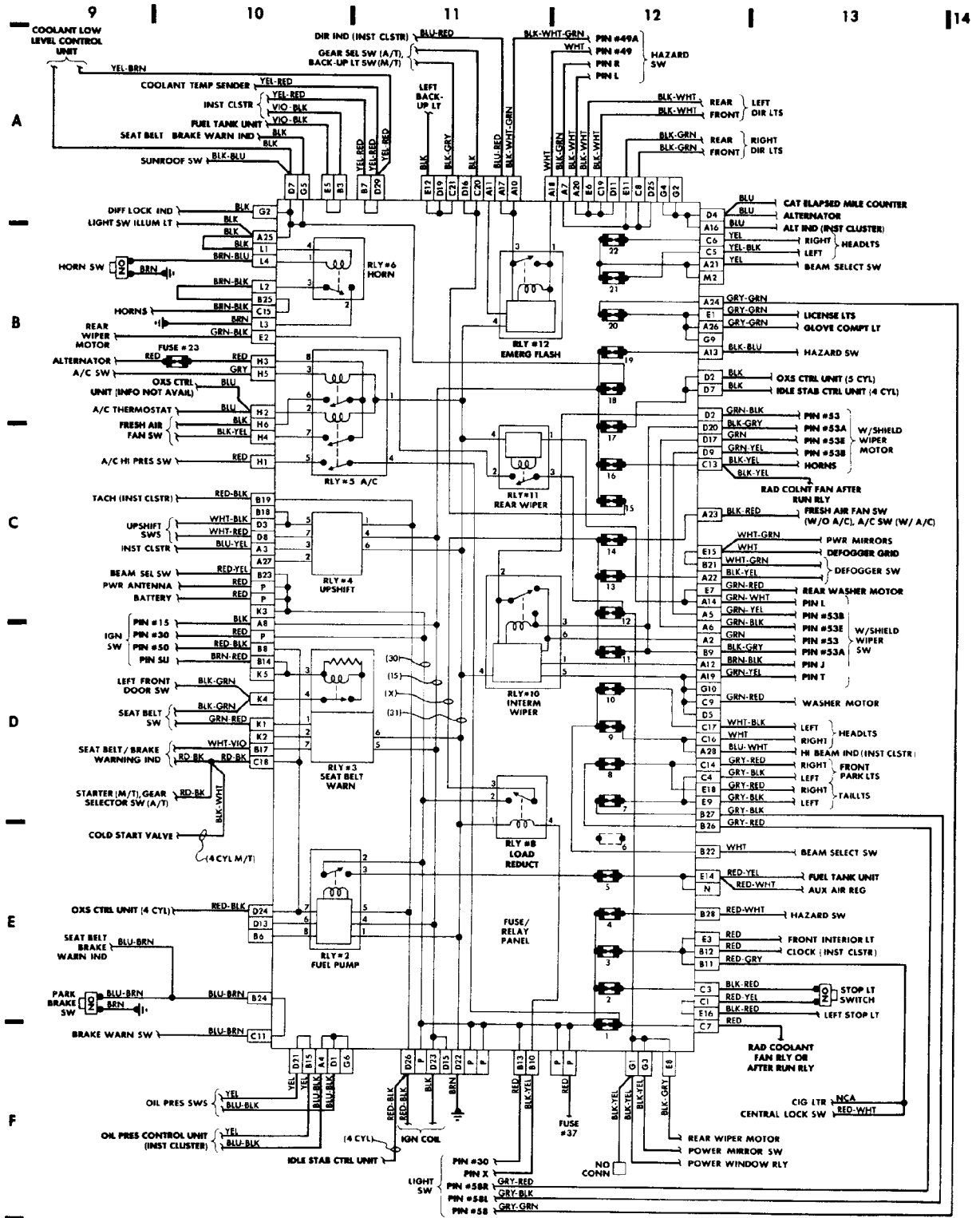

Fig. 3: Underdash (Cont.) & Fuse Block (Grids 9-14)

**WIRING DIAGRAMS**  
**Article Text (p. 6)**  
 1986 Volkswagen Quantum  
 For <http://volkswagen.msk.ru>  
 Copyright © 1998 Mitchell Repair Information Company, LLC  
 Sunday, January 28, 2001 11:53PM

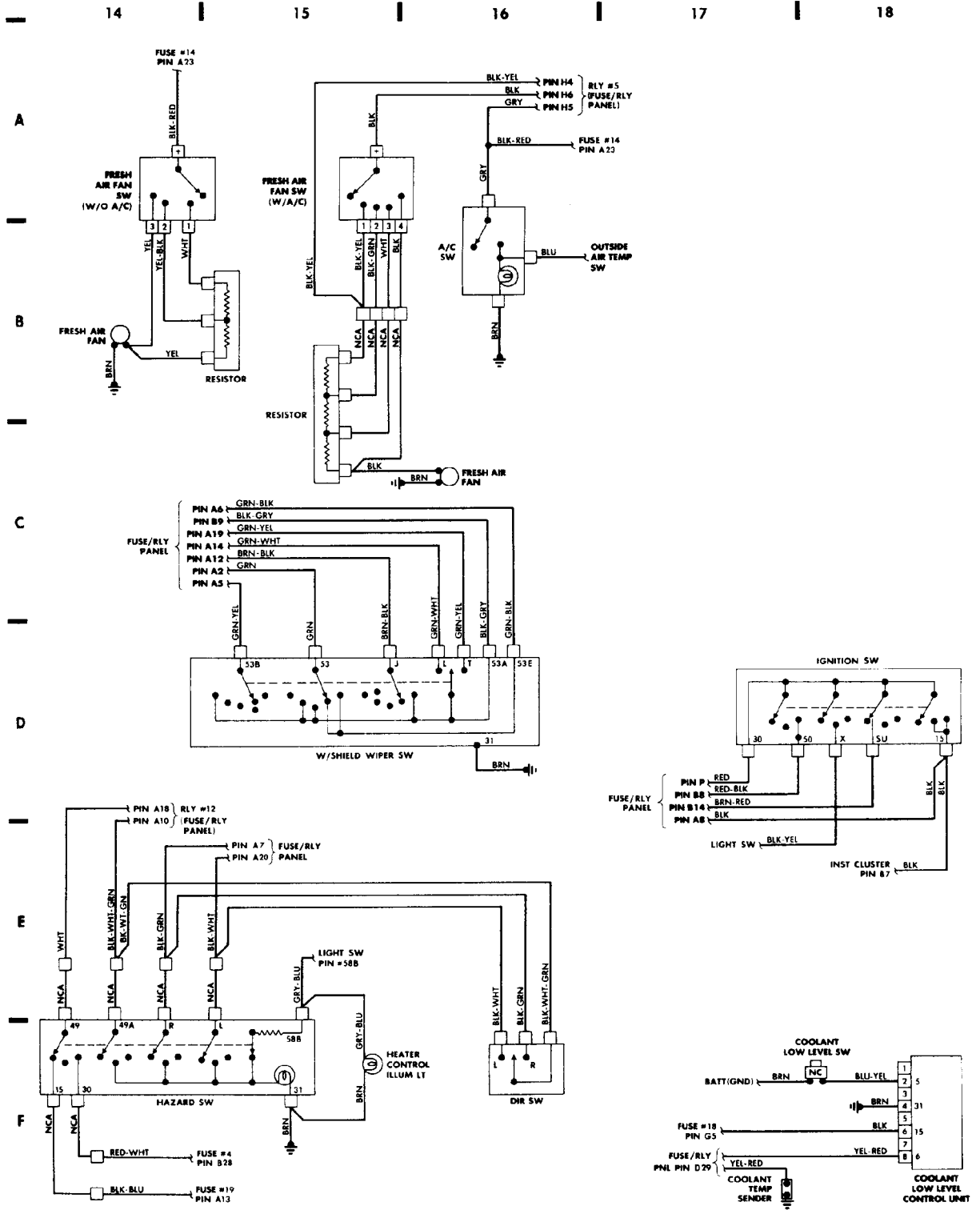

Fig. 4: Underdash (Cont.) & Instrument Panel (Grids 14-18)

**WIRING DIAGRAMS**  
**Article Text (p. 7)**  
 1986 Volkswagen Quantum  
 For <http://volkswagen.msk.ru>  
 Copyright © 1998 Mitchell Repair Information Company, LLC  
 Sunday, January 28, 2001 11:53PM

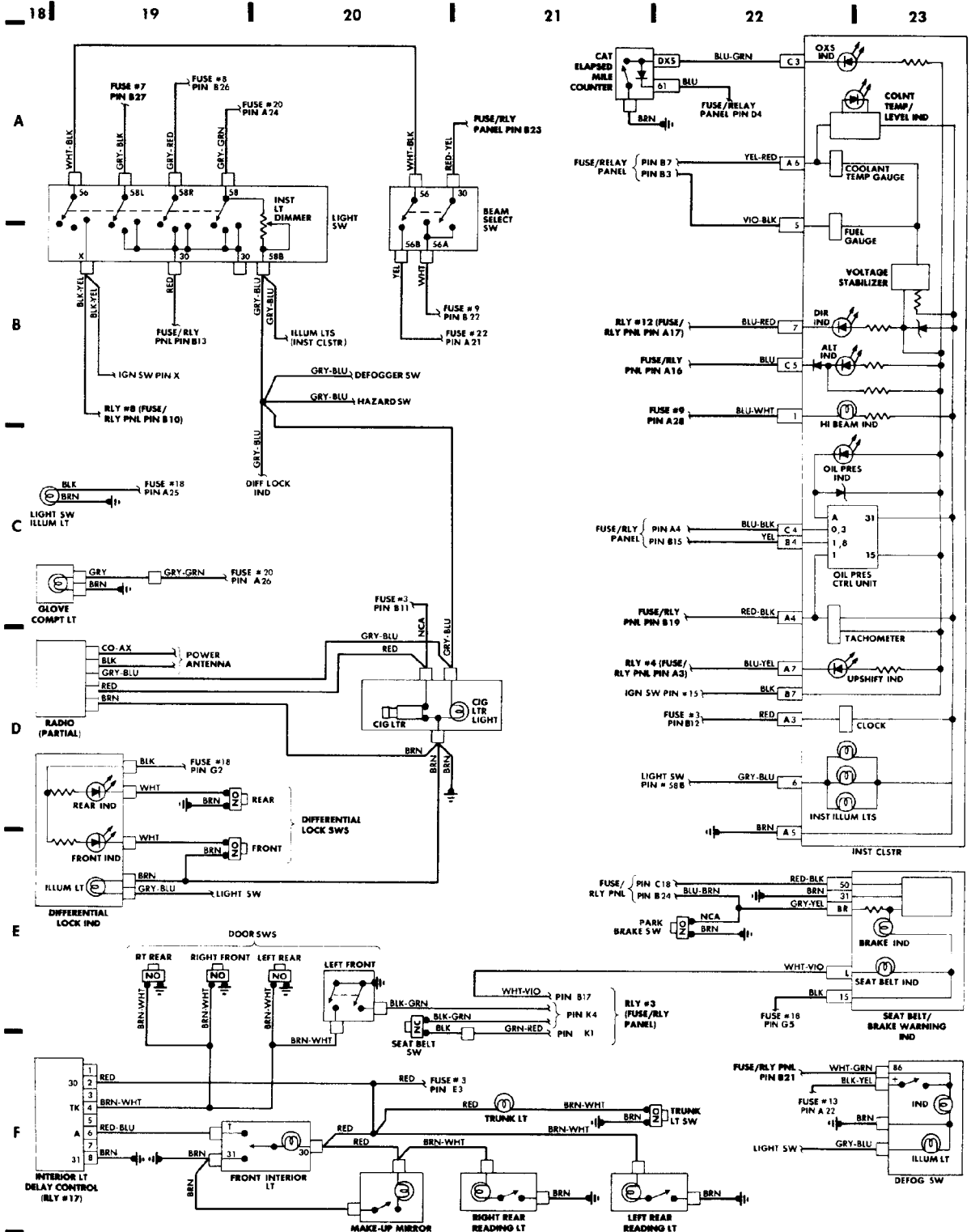

Fig. 5: Instrument Panel (Cont.) & Rear Compartment (Grids 18-23)

**WIRING DIAGRAMS**  
**Article Text (p. 8)**  
 1986 Volkswagen Quantum  
 For <http://volkswagen.msk.ru>  
 Copyright © 1998 Mitchell Repair Information Company, LLC  
 Sunday, January 28, 2001 11:53PM

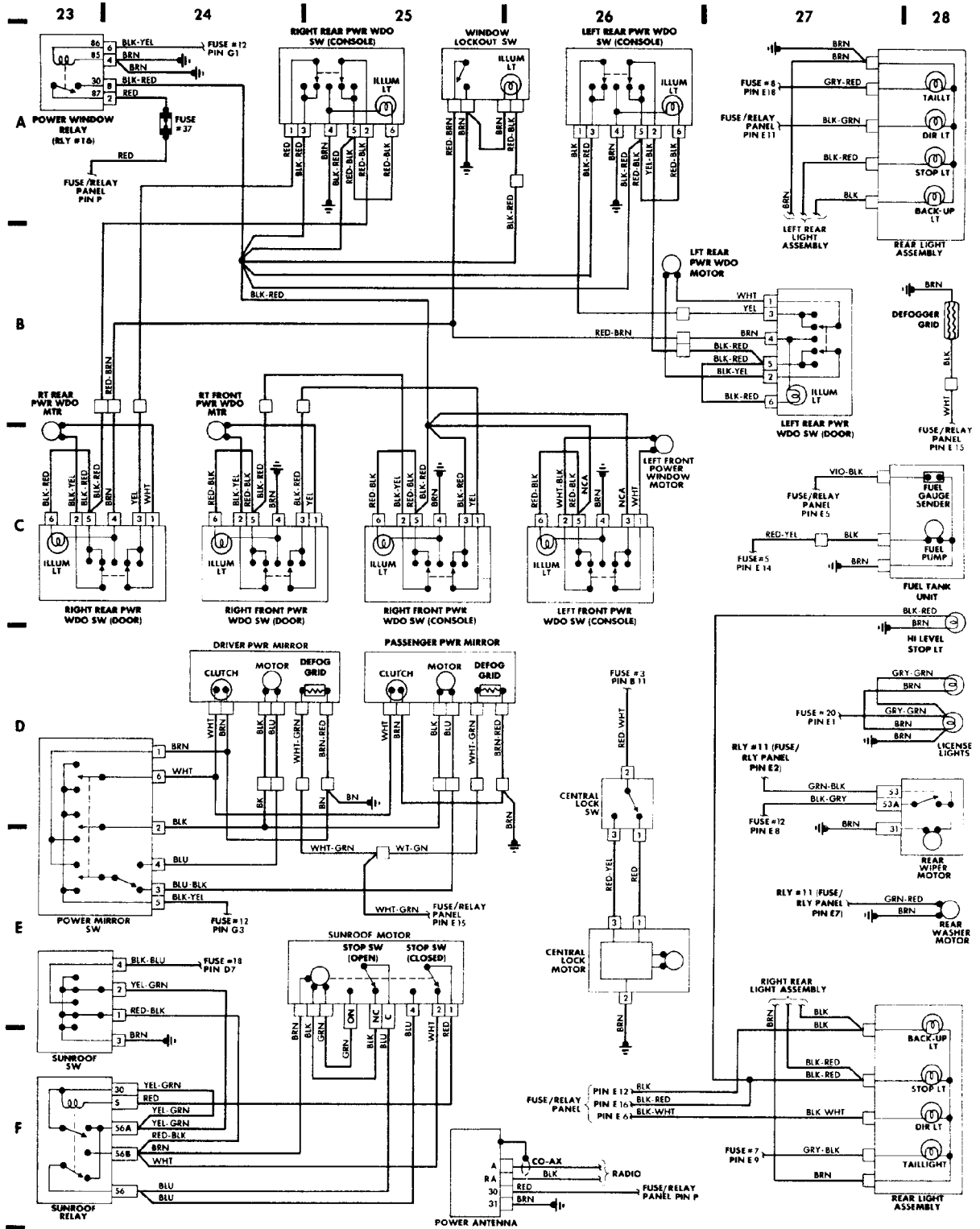

Fig. 6: Rear Compartment (Cont.) & Accessories (Grids 23-28)

END OF ARTICLE